

## TROUBLE SHOOTING GUIDE

The unit should be calibrated with the vehicle as close to level as possible. If you are installing it on a boat, it should be at the level it will be at in the water. Depending on where the sensor strips are located on the tank, the readings may be somewhat sensitive to the pitch of the vehicle (due to the fluid sloshing either against or away from the sensor elements mounted to the tank wall). Keep this in mind when interpreting what otherwise might be a malfunctioning sensor or display.

Some tanks, particularly those mounted below the decks in boats, may be impossible to completely drain or may refill with a small amount of fluid after pumping out (due to fluid left in the drain plumbing, which may drain back into the tank). If you calibrated empty on such a tank when it was completely dry (as in a factory installation) it may read that there is some fluid in the tank even when pumped empty. If this is the case simply recalibrate the empty point after pumping out and allowing to "SETTLE" to an actual "EMPTY" level. See Step 4.

### PROBLEMS & REMEDIES

Problem	Possible Causes	Test/Remedy
Tank always reads full, empty or never changes regardless of level of fluid in the tank.	-Improperly Calibrated Tank -Damaged wiring between display, sensor module and/or power source. -Damaged or improperly installed sensor foil -Damaged sensor module -Electrical shock to the system via outside source or incorrect wiring, frying sensors and/or panel	-Recalibrate tank for empty and full and recheck -Visually check all of the wire between the sensor, display panel and power source. Check that all wires are attached properly and that there is no damage. Repair any problem and recheck
Tank always reads full	See above or: Sensor ground has been lost	See above or check all ground wiring to make sure securely attached.
Tanks have inaccurate readings	-See above or: -You may have too much or too little aluminum tape on your tank.	See above or add or remove tape, recalibrate and check again. To remove tape, use a razor blade and run it from top to bottom. Use a ruler to keep a straight line.

### 12V DC Power

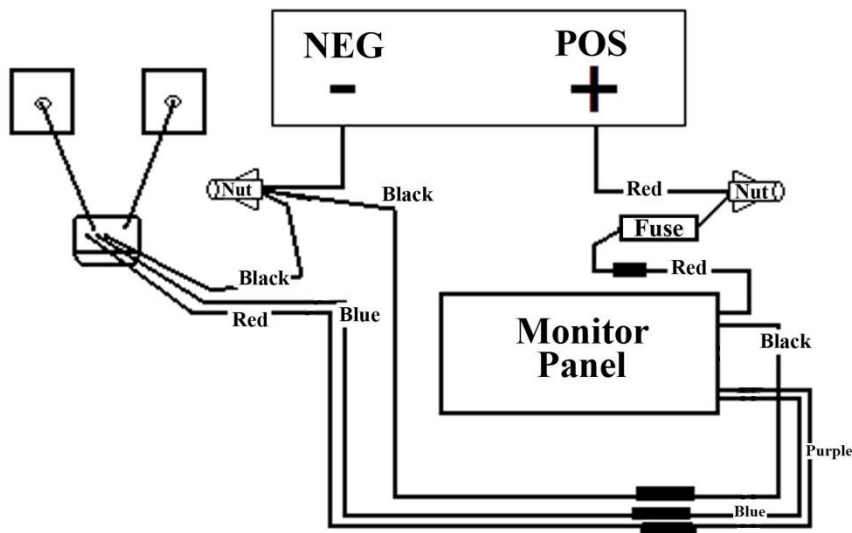

## INSTALLATION INSTRUCTIONS AND USER GUIDE FOR YOUR SMART MINI TANK MONITOR

### Thank you for your purchase!

Tech-Edge Manufacturing's full line of Tank Monitor systems are designed to enhance tank efficiency and quality of life, while granting an easy, hassle free user monitor system.

#### PLEASE READ ALL INSTRUCTION BEFORE USING MONITOR

These installation instructions are written to have as universal an application as possible. Most installations are performed easily using simple hand tools. If you encounter any questions or difficulties please contact your place of purchase or your local RV/Marine service center for professional installation. You are also welcome to call our Tech Support line. Whenever the word CAUTION appears in these instructions, the following item needs to be performed EXACTLY as written. Failure to do so can result in injury to yourself or others, damage to your RV or Boat or failure of the Monitor to work properly. NOTE: Any alteration to the Monitor kit will void your warranty.

\*\*\**SAVE THESE INSTRUCTIONS*\*\*\*

#### KIT INCLUDES:

SMART MINI TANK MONITOR · EXTERIOR TANK MODA SENSOR (for non-metal holding tanks) · FUESABLE LINK WITH ½ AMP FUSE · 4½' ROLL FOIL TAPE · BUTT CONNECTORS

#### POSSIBLE TOOLS NEEDED FOR INSTALL:

DRILL · 1/8" DRILL BIT · TAPE MEASURE · LEVEL · ELECTRICAL TAPE · BOX CUTTER/SCISSORS · VOLTAGE TESTER · HAND/JIG SAW · 18 GUAGE HOOK UP WIRE · WIRE CUTTERS · ADDITIONAL BUTT CONNECTORS OR WIRE NUTS · ISOPROPAL ALCOHOL · 3M-SPRAY, OR ANY OTHER NON-CONDUCTIVE ADHESIVE  
IF YOU NEED CUSTOM INTERIOR TANK RODS FOR METAL TANKS, YOU CAN ORDER THOSE DIRECTLY FROM THE MANUFACTURE AT THE NUMBER LISTED ON PAGE 3.

### STEP ONE:

**Location and installation of Monitor Panel:**

**CAUTION: READ CAREFULLY**

Choose a panel location that is convenient to see and reach, and that does not interfere with drawers, cabinets, existing wiring, etc. In choosing a location you must also give major consideration to the fact the WIRES must be routed from the panel to the holding tanks as well as to your power source. MAKE CERTAIN the proposed wiring routes are not blocked by wall stringers or other structural supports.

Cut out hole should be about 2½" x 1½". Mark holes on the corners of the area to be cut out. Cut the panel opening as indicated. The panel will attach to the wall with 4 screws at the corners. **DO NOT** attach the panel to the wall until all other installation, calibration and testing has been completed.

## STEP TWO

### INSTALL SENSORS ONTO THE TANK(S):

NOTE: This section covers the installation of our external sensor modules called MODA sensors. If you have our custom made internal rod sensors (PVC or aluminum) for metal tanks or tanks that are not accessible to the side wall, installation will be different but wiring will be the same.

An external sensor is comprised of two parts: THE FOIL TAPE and the MODA SENSOR MODULE. Refer to **Figure #2** and repeat the following steps for each tank.

- Measure and cut to length two strips of foil tape. Each strip will run as close to the ends of the tank as possible while still being able to maintain adhesion. If a tank has rough or rounded corners, you may need to bring it in  $\frac{1}{2}$ ". NOTE: Each strip of foil tape should be between 15 and 40 square inches (multiply the length times the width) it may be necessary to trim away or add to the tape width to stay within these parameters.
- Prepare the tank area where the foil tape is to be placed by rubbing down the area with common isopropyl alcohol. Remove the paper backing from the foil tape strips and place them on to the tank in the designated areas. Smooth out any trapped air bubbles. Follow the dimensions on **Figure #2** below.
- If your tank is less than 8" tall or has very thick walls, then you will need to add additional tape and/or bring the tape closer together. If you are adding additional tape width, see **Figure #2 A** below. Foil can be added over the copper pad without a problem as long as it is pressed completely down.

IMPORTANT: The foil tape strips must be an inch or more away from large metal objects such as framework, metal siding, stored items, etc...

Remove the paper backing from the copper pads and from the module. Place a copper pad onto each of the two foil tape strips, then stick sensor to tank. The copper pads can be trimmed if they exceed the width of the foil tape, they can also be placed anywhere UP or DOWN the length of the tape.

- When you have installed the entire system, calibrated and tested it; then, apply a thin coating of 3M-spray (ie. Formula 77 or 90), or any non-conductive adhesive over the top surface area of the exposed tape to help ensure long term adhesion (optional).

IMPORTANT: PROVIDE ADEQUATE VENTILATION WHEN APPLYING THE ADHESIVE, PARTICULARLY IF WORKING IN A CONFINED AREA.

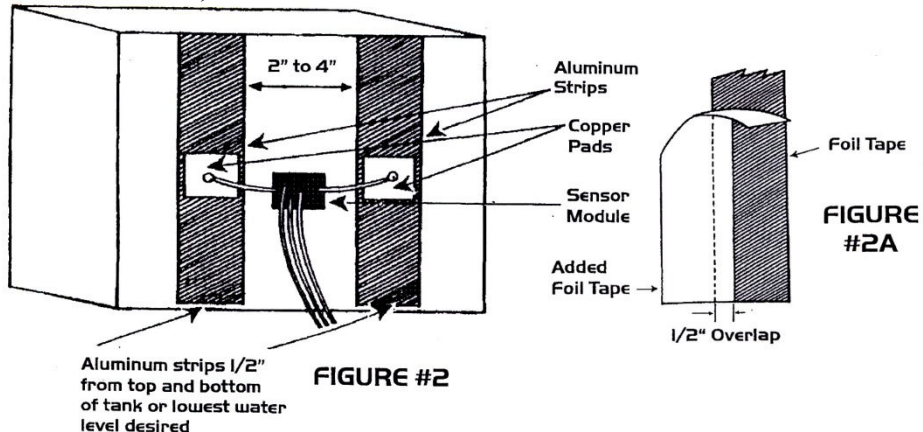

## STEP THREE

**RUN WIRING : “CAUTION”** If you use staples or nails to secure wiring, make sure you **do not** penetrate the wire at all. Also route wires so they do not interfere with storage areas and away from potential sources of heat (oven, exhaust pipes, etc.). Due to the vast range of application possibilities it is not practical for us to include hookup wire in the kit. It is however, commonly available and inexpensive. You must use at least 18 gauge stranded wire for the power runs and between 22 and 18 Awg for the data runs. Make certain you have enough to perform all connections.

You will be using your hookup wire to make connections to a 12 volt D.C. power source and for connecting the panel to the tank(s). After studying the wiring installation procedures you can cut your hookup wire to required lengths, then strip the insulation on all wire ends approximately  $\frac{1}{4}$ " and use the supplied butt connectors or wire nuts to join wires. Take time to study the **wiring diagram on the back page** and the “Hookup Guide” below.

### HOOKUP GUIDE:

- The first connections are made to the purple and blue wires which are routed to tank. Purple on the panel to Red on the sensor. Blue on the panel to Blue on the Sensor.
- CAUTION** - When have hooked up the tanks, you can then hook up the Red Wire on the panel to the fuse assembly which then runs to the 12 volt DC Positive (Make sure the fuse is in the assembly and looks good prior to hooking up. Black on the panel should then be run to the 12 volt DC Negative (ground). **Do not hook these up wrong or the panel and/or sensor will be severely damaged!**
- The black wire on the Sensor can be attached to the black wire from the panel or grounded.

## STEP FOUR

### CALIBRATE PANEL:

This panel features our SMART CHIP calibration algorithm. This should eliminate sensor installation issues and greatly simplify tank calibration. Review the instructions below completely before attempting calibration.

Note: You can calibrate either empty or full first but you need to have the tank at the level you want calibrated (i.e. empty for empty or full for full).

When you are calibrating the empty level, start with an empty tank. Press and hold the tank reading button. While you are holding the tank reading button, press and hold the empty calibration button for 5 seconds (this button is marked with an “E”) The lights should then note you have an empty tank..

When you are calibrating the full level, fill the tank with water. Repeat the same procedures above but press the “F” button. The lights should then note you have a Full tank.

If you are not able to diagnose and fix your problem, please check our web site for more troubleshooting information and videos. If that does not help you, please feel free to contact our tech-support.



4296 Osage St. · Sweet Home · OR · 97386  
(541) 610-0401  
www.TankEdge.com