



**INSTALLATION INSTRUCTIONS AND USER
GUIDE FOR YOUR iSERIES TANK MONITOR**
Software Version 2025-6X2-1 · 12 Volt System



Thank you for your purchase!

Tech-Edge Manufacturing's iSeries Monitor is designed to enhance tank efficiency and quality of life, while providing an easy, hassle free monitoring system.

PLEASE READ ALL INSTRUCTIONS BEFORE USING MONITOR

Later instructions might have an impact on your starting procedures. These installation instructions are written to have as universal an application as possible. Most installations are performed easily using simple hand tools. If you encounter any questions or difficulties that cannot be answered from this manual or online, please contact your place of purchase or your local RV/Marine service center for professional installation. You are also welcome to call our Tech Support line. Whenever the word CAUTION appears in these instructions, the following item needs to be performed EXACTLY as written. Failure to do so can result in injury to yourself or others, damage to your RV or Boat or failure of the Monitor to work properly. NOTE: Any alteration to the Monitor kit will void your warranty.

*****SAVE THESE INSTRUCTIONS*****

STANDARD KIT INCLUDES:

iSERIES TANK MONITOR · 3 EXTERIOR MODA TANK SENSORS ·
INLINE FUESABLE LINK WITH ½ AMP FUSE · ROLL FOIL TAPE
(4½' PER TANK- 13½' TOTAL) · 12 BUTT CONNECTORS ·
4 SCREWS · CUT OUT TEMPLATE FOR MONITOR WITH MANUAL

POSSIBLE TOOLS NEEDED FOR INSTALL:

DRILL · 1/8" DRILL BIT · TAPE MEASURE · LEVEL ·
ELECTRICAL TAPE · BOX CUTTER/SCISSORS · VOLTAGE
TESTER · HAND/JIG SAW · 18 GAUGE HOOK UP WIRE ·
WIRE CUTTERS · ADDITIONAL BUTT CONNECTORS ·
ISOPROPAL ALCOHOL · 3M-SPRAY (Formula 77 or 90) OR ANY
OTHER NON-CONDUCTIVE ADHESIVE (optional) ·

**IF YOU NEED MORE EXTERIOR MODA SENSORS OR
CUSTOM INTERIOR TANK RODS FOR METALLIC TANKS,
YOU CAN ORDER THOSE DIRECTLY FROM TECH-EDGE
MANUFACTURING LISTED ON THE BACK.**

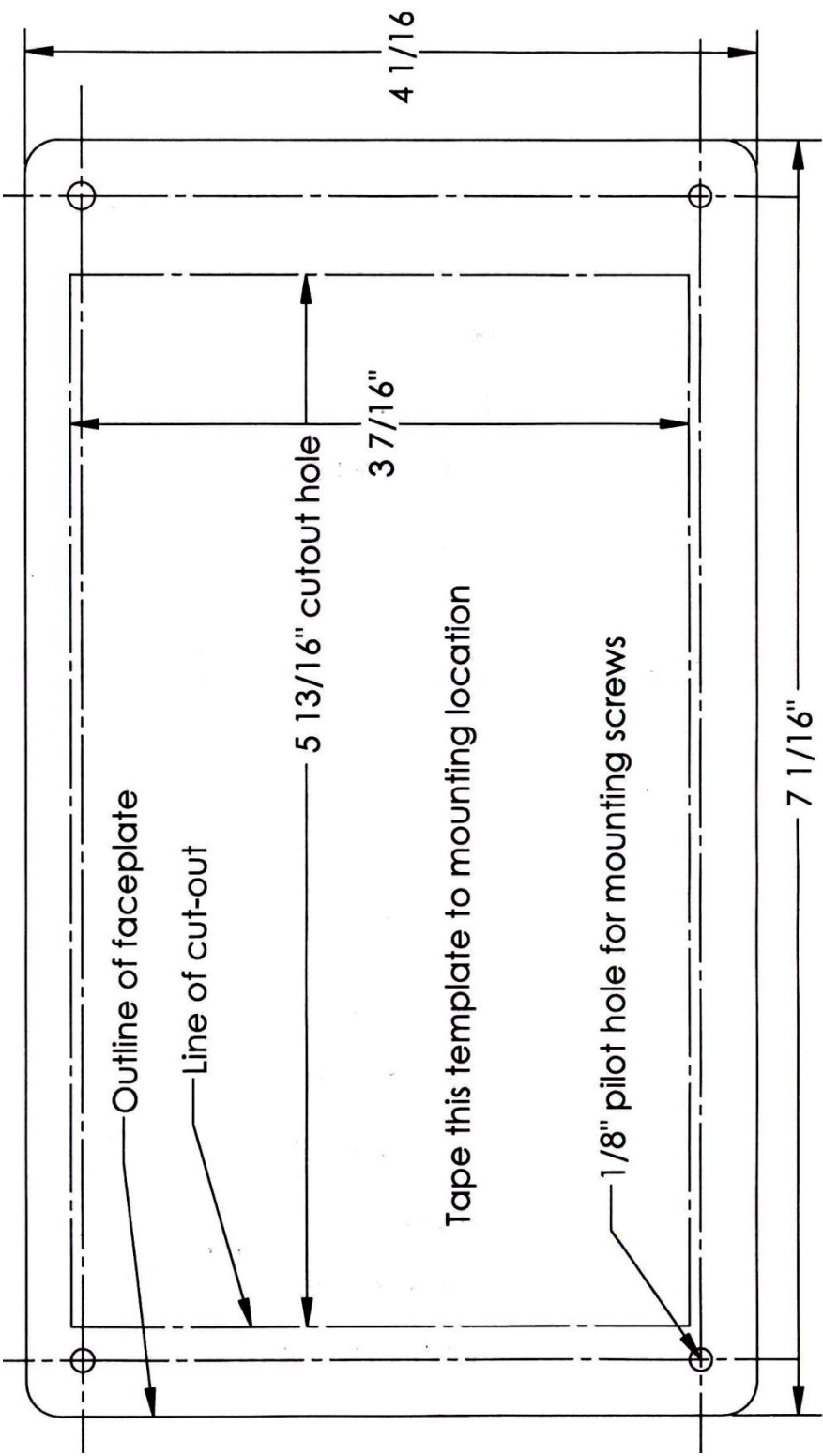

Outline of faceplate

Line of cut-out

$5 \frac{13}{16}$ cutout hole

$3 \frac{7}{16}$ "

$4 \frac{1}{16}$

Tape this template to mounting location

$\frac{1}{8}$ " pilot hole for mounting screws

$7 \frac{1}{16}$ "

STEP ONE:

Location and installation of Monitor Panel:

CAUTION: READ CAREFULLY

Choose a panel location that is convenient to see and reach, and that does not interfere with drawers, cabinets, existing wiring, etc. In choosing a location you must also give major consideration to the fact the WIRES must be routed from the panel to the holding tanks as well as to your power source. MAKE CERTAIN the proposed wiring routes are not blocked by wall stringers or other structural supports.

REFER TO **Cut Out Template on Page 2** If you would like to keep your manual intact, make a 100% copy of the cut out template or print another one out from the manual online and use that. Using the cut-out guide, mark holes on the corners of the area to be cut out as well as the screw placements. Cut the panel opening as indicated. The panel will attach to the wall with 4 screws at the corners. **DO NOT** permanently attach the panel to the wall until all other installation, calibration and testing has been completed.

STEP TWO

INSTALL SENSOR(S) ONTO THE TANK(S):

NOTE: This section covers the installation of our external sensor modules called MODA sensors. If you have our custom made internal rod sensors (PVC or aluminum) for metal tanks or tanks that are not accessible to the side wall, installation will be different but wiring will be the same.

An external sensor is comprised of two parts: THE FOIL TAPE and the MODA SENSOR MODULE. Refer to **Figure #2** and repeat the following steps for each tank.

- A. Measure and cut to length two strips of foil tape. Each strip will run as close to the ends of the tank as possible while still being able to maintain adhesion. If a tank has rough or rounded corners, you may need to bring it in ½". NOTE: Each strip of foil tape should be between 15 and 40 square inches (multiply the length times the width) it may be necessary to trim away or add to the tape width to stay within these parameters. **Always start with your tape approximately 2" apart especially on smaller tanks.**
- B. Prepare the tank area where the foil tape is to be placed by rubbing down the area with common isopropyl alcohol. Remove the paper backing from the foil tape strips and place them on to the tank in the designated areas. Smooth out any trapped air bubbles. Follow the dimensions on **Figure #2** below.
- C. If your tank is less than 8" tall or has very thick walls, then you will need to add additional tape and/or bring the tape closer together. If you are adding additional tape width, see **Figure #2A**. Foil can be added over the copper pad without a problem as long as it is pressed completely down.

CAUTION: The foil tape should be an inch or more away from large metal objects such as framework, metal siding, stored items, etc...

Remove the paper backing from the copper pads and from the module. Place a copper pad onto each of the two foil tape strips, then stick sensor to tank. The copper pads can be trimmed if they exceed the width of the foil tape, they can also be placed anywhere UP or DOWN the height of the aluminum tape. Wherever is convenient to place it.

- D. ***When you have installed the entire system, calibrated and tested it; then*** you can apply a thin coating of 3M-spray (ie. Formula 77 or 90), or any non-conductive adhesive over the top surface area of the exposed tape to help ensure long term adhesion if you desire (optional).

IMPORTANT: PROVIDE ADEQUATE VENTILATION WHEN APPLYING THE ADHESIVE, PARTICULARY IF WORKING IN A CONFINED AREA.

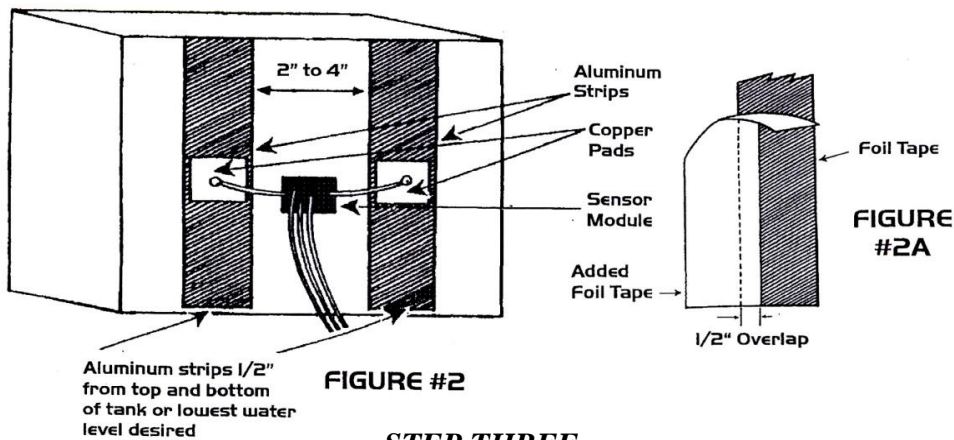

FIGURE #2

FIGURE #2A

STEP THREE

RUN WIRING : **“CAUTION”** You can reuse wiring that is already run if you are doing an aftermarket install, but if you are running new wires follow these instructions. If you use staples or nails to secure wiring, make sure you **do not** penetrate the wire. Also route wires so they do not interfere with storage areas and away from potential sources of heat (oven, exhaust pipes, etc.). Due to the vast range of application possibilities it is not practical for us to include hookup wire in the kit. It is however, commonly available and inexpensive. We recommend at least 18 Awg stranded wire for the power runs and between 22 and 18 Awg for the sensor connections. Using a variety of colors for different connections will simplify troubleshooting any problems. After you have cut your wires to the desired length, you will need to strip each end approximately ¼” to use the supplied butt connectors to connect your wires.

- A. Take time to study the wiring diagram and the “Hookup Guide” on page 5. There are colored pairs of wires for each tank that have red and blue stripes that correspond with the red and blue solid wires on the sensors. Initial set-up of the panel has Tank 1 as Fresh, Tank 2 as Grey and Tank 3 as Black although you can change this if needed.
- B. All the black wires from the sensors need to be grounded very well (together or separate) or run back to the black wire on the panel. **Black wires from Sensors can also be linked together and grounded locally if you have a ground to attach them to (i.e. the chassis)**
- C. **CAUTION** - When you have wired and checked all the tanks, you can then connect the red wire (#1) on the pigtail connector to either terminal on the back of the power switch, the fuse assembly will attach to the other terminal and then run to 12 volt DC Positive (Make sure the fuse is in the assembly and looks good prior to connecting). The black wire (#2) should then be run to 12 volt DC Negative. **Do not hook these up wrong or the panel and/or sensors will be severely damaged!**
- D. If possible, avoid wiring to a converter power source or to wires that power fluorescent lights. This could result in electrical “noise” which may affect accuracy of panel readings.
- E. If you are hooking up tank 7 or 8 on the panel to an **LPG tank** that already has the 90 ohm sending unit inside, there should be 2 wires coming from the tank. One of these wires gets connected to **both** the red and blue stripped wires at tank 7 or tank 8 on the panel (3 wires together) and the other wire from the tank gets grounded. If there is only one wire coming from the tank, connect it to both wires at the panel. **Initial calibration should not be needed for these tanks unless you notice that the readings are off.**

****CAUTION:** After the wiring is complete, if you have exposed wires coming from the extra wires not used on the pigtail, cut the small exposed portion off and individually wrap them in electrical tape. You do not want these wires touching even though they are not in use. You will want to leave the main portion of the wires intact in case you will need to add more tanks at a later time.

****Note: Tanks 1-6** are designed to drive and receive signal from **MODA SENSORS OR OUR CUSTOM BUILT SENSOR RODS**. **Tanks 7-8** are designed for resistive sensors usually on the larger **LPG tanks**. These positions on the iSeries panel will measure from 0 to 240 ohms with 0 being empty and the higher resistance being full. Tanks 7 & 8 are factory calibrated for the 90 ohm sending units on most large propane tanks.

****If you purchased the Integrity 8 iSeries that drives 8 modas and no LPG, then hook up the last 2 tanks the same as the first 6.**

PIGTAIL COLOR CODE AND HOOK-UP GUIDE / INITIAL CALIB. #'S

DESCRIPTION	WIRE	COLOR/STRIPE	MODA COLOR	CALIB. EMPTY	FULL
POWER 12VDC+ 1		RED	NONE		
GROUND 12 V- 2		BLACK	NONE		
TANK ONE	3	YELLOW/BLUE	BLUE	_____	_____
	4	YELLOW/RED	RED		
TANK TWO	5	ORANGE/BLUE	BLUE	_____	_____
	6	ORANGE/RED	RED		
TANK THREE	7	PURPLE/BLUE	BLUE	_____	_____
	8	PURPLE/RED	RED		
TANK FOUR	9	WHITE/BLUE	BLUE	_____	_____
	10	WHITE/RED	RED		
TANK FIVE	11	GREEN/BLUE	BLUE	_____	_____
	12	GREEN/RED	RED		
TANK SIX	13	GREY/BLUE	BLUE	_____	_____
	14	GREY/RED	RED		
TANK SEVEN	15	BROWN/BLUE	LPG wire	_____	_____
	16	BROWN/RED	together	(pre-calibrated at 0 & 90)	
TANK EIGHT	17	PINK/BLUE	LPG wire	_____	_____
	18	PINK/RED	together	(pre-calibrated at 0 & 90)	

12V DC Power

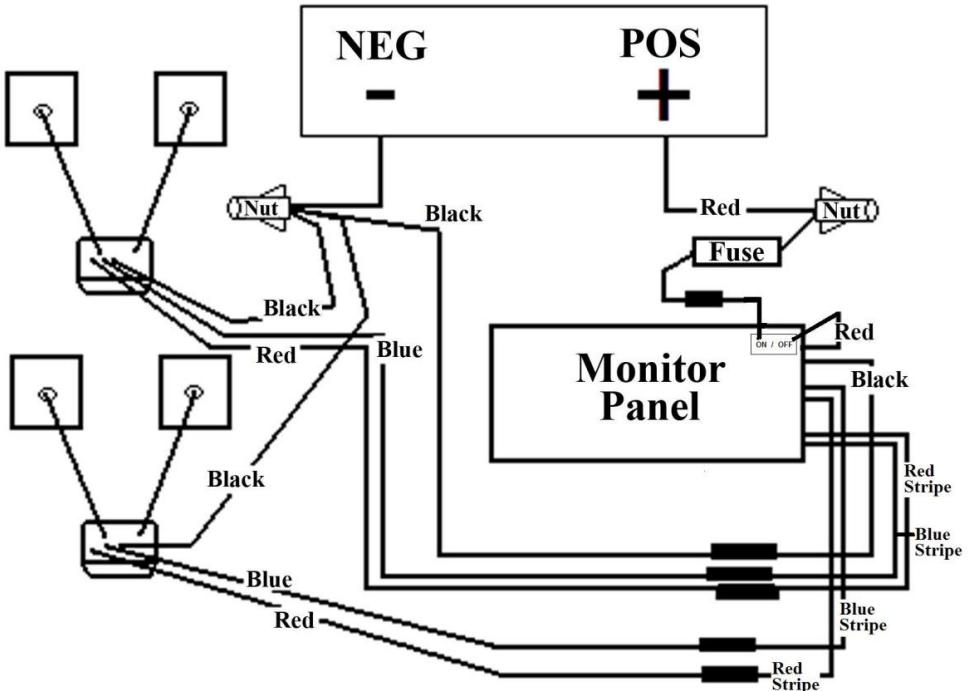

STEP FOUR

***CONFIGURE AND CALIBRATE TANKS (Make sure your vehicle is level):** There are two ways to get into the set-up menu on the iSeries. You can either; press and hold the “Menu” button while turning the power on *or* after the initial tank scan, you can press and hold the “Menu” button for three seconds. After you are in the set-up menu, you can now press the “▲” or “▼” arrows to scroll between menu items. Just a general note; The “OK” button will select the option you are on and pressing the “Menu” button will *usually* back you out of the option you are on. You may have to press the “Menu” button several times to fully back you out to the main menu.

***ENABLE TANKS** – To enable or disable each tank, press “OK” at the “ENABLE TANKS” screen. The numbers on the top row are for each tank corresponding to how you wired them, the “Y” and “N” under each tank denotes whether that tank is enabled or not. The blinking cursor will be on the Y under tank number 1. If you would like to enable tank one, press the “▲” arrow, press the “▼” arrow to disable it. The cursor will then move to tank number two. Continue with until each tank has been enabled or disabled. When finished press the “OK” button or the “MENU” button to exit and save. The next configuration menu item will be displayed.

*** NAME YOUR TANKS** – Press “OK” at the “NAME TANKS” screen to name your tanks. “NAME TANK 1” will appear on the top line and tank one’s current name will appear on the second line. Tanks 1 through 3 are preset with the names 1= Fresh Tank, 2 = Grey Tank, 3 = Black Tank and tank 7 is preset with the name “Propane Tank”. You can change any tank name including preset names. Pressing the “▲” or “▼” buttons will scroll through the tanks. Press the “OK” button when the tank you want to name is displayed, i.e. “NAME TANK 1”. The word “Fresh” will appear on the second line. There are two words to select for each tank. Pressing the “▲” or “▼” will run you through the available names of the tanks for the first word and pressing the “OK” button will toggle to the 2nd word. You can then scroll by pushing the up and down arrows. To give your tank a custom name press the “▲” or “▼” button until “Custom Name” appears on the second line. Press the “OK” button to begin spelling the name for your tank. Use the “▲” and “▼” buttons to scroll through the alphabet, press the “OK” button to select the letter. The cursor will move to the next space. You can continue to spell out the name. There is a maximum of 15 characters. Press the “MENU” key when you are finished spelling the name. You will be prompted to save the name. Press the “OK” button to save it or any other button to disregard the changes. You can then repeat the process for the other tanks by scrolling through the other tanks with the “▲” and “▼” arrow buttons and pressing “OK” to select the tank. When you are finished naming all the tanks, press the “MENU” button to return to the Configuration menu.

***CALIBRATE YOUR TANKS** – Press “OK” at the “CALIBRATE TANKS” screen to calibrate your tanks. **There are four types of calibration.** The first calibration type is “EMPTY/FULL” (Most tanks will use this setting). This is used when you have a tank with straight regular sides. The second type is **25% Increments**. This type is used when your tank has slightly irregular sides or shape. The third type is **10% Increments**. This type is used for tanks that have extremely irregular sides or shape. The last type is “Manual Input”. This is not for setting your initial calibration so do not select this option. It is available to manually adjust individual calibrations to correct issues you may come across, normally, only when you talk to our tech support department.

You can use different calibration types for each tank. Use the “▲” and “▼” buttons to scroll through the calibration types. Press the “OK” button to select the calibration type.

****Prior to selecting the calibration method, please read the Calibration notes at the top of page 8 so you will know what raw reading you are shooting for and what you can do to get a better calibration setting.**

To calibrate using the “EMPTY/FULL**” calibration you can start with the tank either empty or full. You need to have the tank at the level you want calibrated (i.e. empty for empty or full for full). You will need to calibrate both empty and full. The first screen that comes up is the first enabled tank. On each tank, there are three numbers. The 1st number is the Empty calibration number, the 2nd (middle) is the Raw or Live reading and the 3rd is the Full calibration number. If you are calibrating the empty reading, at this screen, you will push the “▼” arrow. If you are calibrating full, press the “▲” arrow. It will ask you if you are sure. Press the “OK” for Yes and “MENU” for No. The raw number should then match the level you just calibrated (i.e. left number for empty or right number for full). When you are filling your tank, you should be able to see the raw number increase. After saving both the empty and full calibration values, push the “MENU” button to back out until you get to the screen where the raw reading in the middle is blinking. Then scroll to the next tank.

To calibrate using the “25% Increments**” it is easiest to start with the tank empty. Press the “OK” button to select the “25% Increments”. The second line will display “EMPTY” and then the current value for the empty calibration. At the end of the line the raw (live) value will be displayed. Press the “OK” button to accept the “Empty” calibration. You will be prompted to save the value. Press the “OK” button to save it or the “MENU” button to disregard the value. The 25% calibration value will then be displayed. You can then calibrate for 25% or “▲” or “▼” to a different level. To calibrate the 25% level, fill the tank to the 25% level. (i.e. if you have a 100 gallon tank put 25 gallons in it). Then press the “OK” button to accept the 25% value. Continue this pattern for the 50%, 75% and Full values. You must set calibration at each level. When you finish the “Full” level, you can press the menu button to back out of the calibration for that tank until you get to the screen where the raw reading in the middle is blinking. Then scroll to the next tank.

To calibrate using the “10% Increments**” it is easiest to start with the tank empty. Press the “OK” button to select the “10% Increments” calibration. The second line will display “EMPTY” and then the current value for the empty calibration. At the end of the second line the raw (live) value will be displayed. Press the “OK” button to accept the “EMPTY” calibration. You will be prompted to save the value. Press the “OK” button to save it or the “MENU” button to disregard the value. The 10% calibration value will then be displayed. You can then calibrate for 10% or “▲” or “▼” to a different level. To calibrate the 10% level, fill the tank to the 10% level. (i.e. if you have a 100 gallon tank put 10 gallons in it). Then press the “OK” button to accept the 10% value. Continue this pattern for the 20%, 30%, etc. You must set calibration at each level. When you complete the “Full” calibration setting, you can press “menu” to back out of the calibration for that tank until you get to the screen where the raw reading in the middle is blinking. Then scroll to the next tank.

To adjust an individual calibration value after you have initially calibrated your tanks, select the tank to calibrate then press the “▲” or “▼” buttons until you see “MANUAL INPUT**” then press the “OK” button. This should only be done after your initial calibration is input. This is not recommended for most installations. At this point you can scroll to the calibration value you wish to adjust by pressing the “▲” and “▼” buttons. When the calibration value you wish to change appears press the “OK” button. This will enable you to make adjustment to the value by using the “▲” and “▼” buttons. You can tell when you are in the adjustment mode by the up and down arrows in the bottom right corner of the LCD screen. After adjustment is complete press the “OK” button. You will be prompted to save the value or disregard the value. After saving the calibration value you will return to the screen where you can select another calibration value to adjust.

****Calibration notes:** *You want a minimum difference of at least 50 count between the Empty calibration and the Full calibration settings (It will work at less than that but it is not optimal). Ideally you would like to shoot for closer to 100 count difference. This is not absolutely necessary but the higher the difference, the better the accuracy. You also want to try and keep your full number under 250. If the difference between your empty and full calibration settings is quite a bit less than 50, you can add foil to the inside of your original foil strips. This will bring the strips closer together and should increase your count. Do only one side at a time and check your number. Make sure you overlap the foil and it stays pretty consistent the whole height of the tank. It is OK to cover some of the copper tape. If you have a very short tank (i.e. 6" or so) or a very thick tank you might have to add a second strip of foil overlapping the first one on the outside of each strip. Space is provided on page 4 to note your initial calibration settings for future tech support needs. If you end up getting non-linear readings when you are checking your tanks, you may have to change from Empty/Full calibration to the 25% or 10% calibration settings; especially for irregular shaped tanks.*

*** CONFIGURE YOUR ALARMS** – Press “OK” at the “TANK ALARMS” screen to configure your alarms. The first screen will be your first enabled tank. You can now toggle the alarm on or off (“Disabled” or “Enabled”) by pushing the “▼” arrow. You can toggle between being alarmed at Empty (Low) or Full (High) levels by pushing the “▲” arrow. (i.e. “Low” for Fresh or Fuel tanks and “High” for Grey or Black tanks).

****You should note that pressing the “Menu” button here scrolls through each tank for changes instead of pushing the “▲” or “▼” arrows.** When you press “OK” at a tank that you have enabled the alarms on, it will bring up the “alarm at” level screen. This screen will not appear if the tank alarm is not enabled. Press the “▲” or “▼” arrows to select the percentage you would like to be alarmed at. (i.e. If you want the Fresh Tank to alarm you when it reaches 15% empty, push the “DOWN” arrow until you reach 15). Press the “OK” button when you have selected your percentage. The next enabled tank will be displayed. After all tank alarms are configured, pressing “OK” will bring you to “ALARM VOLUME” press the “▲” or the “▼” button to set the alarm level. The level can be set from 0 (off) to 255 (max volume level). Press the “OK” button to go to the set up step.

*** CONFIGURE TANK SCANNING FREQUENCY** – After you configure your alarms you will automatically be brought to the next configuration screen “TANK SCAN FREQ”. Press “OK” here to set your scanning frequency. Press the “▲” or “▼” arrows to change the amount of time between automatic scans of the tank levels. If you select “AUTO SCAN OFF”, no automatic scans will be done and tanks will only be checked during manual tank checks. Press “OK” when desired time is selected.

*** SELECT BRIGHTNESS OF BACKLIGHT** – Press “OK” at “SCREEN BRIGHTNESS” to change the brightness of your LCD screen. Press the “▲” or “▼” arrows and then press “OK” when done.

*** ENABLE BATTERY ALARM AND SELECT VOLTAGE FOR BATTERY ALARM** – Press “OK” at the “BATTERY ALARM” screen to enable or disable the battery alarm. If the alarm is enabled pressing the “OK” button will take you to the battery alarm voltage level screen where you can set the voltage level your battery alarm will sound at. Press the “▲” or “▼” arrows until desired voltage is reached then press “OK” to save the alarm level.

*** SOFTWARE VERSION** – this screen will tell you what version of software you are using. In our continuous efforts to be the best product on the market, free software upgrades are available for the life of your tank monitor panel as long as there are no hardware changes. Any charges for hardware changes to accommodate any updates will be minimal.

Press the “▲” or “▼” arrows to change more configurations or the “MENU” button to exit configuration mode.

USING THE SYSTEM

After the system is all wired and configured, you can screw in your panel and enjoy the most accurate tank monitoring system on the market.

The screen for your monitor will be off unless you are manually scanning the levels of your tanks. To check the level of your tanks, press the “▲” or “▼” arrows to scroll through each tank. The display usually will not come on when it is doing an automatic scan. You can also do a full scan if you press both the “▲” and “▼” arrows at the same time. If during an automatic scan or a manual scan a tank reads out of bounds (empty or full), the alarm will sound.

SILENCE ALARMS – To temporarily silence an alarm until the next scan, press the “OK” button. If you want to fully disable an alarm for one tank, you will do that through the configuration menu (see “Tank Alarms” above). To silence *all* the alarms completely, you will need to press the “MENU” and the “OK” buttons at the same time. This will bring you to “AUDIBLE ALARMS” screen. Pressing the “▼” arrow will silence *all* alarms, pressing the “▲” button will enable *all* alarms. When you are scrolling through your tanks, it will state “AUDIO ALARMS DISABLED” and then the alarm level “LEVEL LOW” or “LEVEL HIGH”. To turn the alarms back on press the “OK” and “MENU” buttons at the same time. Then press the “▲” button to re-enable all the audible alarms.

TROUBLESHOOTING GUIDE

Factors affecting the accuracy of readings and calibration.

The unit should be calibrated with the vehicle as close to level as possible. If you are installing it on a boat, it should be at the level it will be at in the water. Depending on where the sensor strips are located on the tank, the readings may be somewhat sensitive to the pitch of the vehicle (due to the fluid sloshing either against or away from the sensor elements mounted to the tank wall). Keep this in mind when interpreting what otherwise might be a malfunctioning sensor or display.

Some tanks, particularly those mounted below the decks in boats, may be impossible to completely drain or may refill with a small amount of fluid after pumping out (due to fluid left in the drain plumbing, which may drain back into the tank). If you calibrated empty on such a tank when it was completely dry (as in a factory installation) it may read that there is some fluid in the tank even when pumped empty. If this is the case, simply recalibrate the empty point after pumping out and allowing to settle to an actual “EMPTY” level. See step 3 on page 6.

If you are not able to diagnose and fix your problem, please check our web site for more troubleshooting information and videos. If that does not help you, please feel free to contact our tech-support.



4296 Osage St.
Sweet Home · OR · 97386
(541) 610-0401 · (541) 367-3116 Fax

www.TankEdge.com

PROBLEMS & REMEDIES

Problem	Possible Causes	Test/Remedy
One or more tanks always read full and the raw reading never changes, usually over 250.	Ground wire has probably become disconnected.	Check the ground wire at each sensor that is not working. Sometimes they are all tied together. Reconnect or fix and check raw reading. You can check voltage across the blue wire and ground wires; if the pulsing signal is close to 10 volts while the panel is checking that tank, the ground is probably loose or disconnected somewhere.
Raw reading is always between 27 and 45 no matter what is in the tank. It does not change	*If it does not change at all, your red and blue wires are probably reversed *if it changes some but not very much, you might need to adjust the foil on the tank. (See notes on page 8).	The red stripped wire at the panel should always go to the red wire on the sensor and the blue stripped wire should always go to the blue wire on the sensor. This can also be checked by measuring with a volt meter across the blue and the black wire, at the sensor, while the panel is at that tank. If the pulsing signal reads around 10 volts than your wires are crossed.
Tank always reads full, empty or never changes regardless of level of fluid in the tank.	Improperly Calibrated Tank (see calibration section on pages 6-8)	Check to see if the raw (live) reading is <i>in between</i> the empty and full settings. Make sure the empty and full calibration settings are not the same or very similar. If so, recalibrate tank for empty and full and recheck. Make sure the raw reading is changing as you are emptying and filling the tank.
	Damaged or improperly installed aluminum foil tape	Visually check the foil installation on the outside of your tank. Make sure it is completely attached from the top to the bottom and there are no tears or bubbles. Reinstall tape or add new tape to correct problems
	Damaged sensor module	Make sure white wires are securely attached to the copper pads on the tanks. If they have come loose, you can order a repair kit from the web site or using the order form. Further moda sensor testing instructions can be found on the web site.
	Electrical shock to the system via outside source or incorrect wiring, frying sensors and/or panel	Use the moda sensor testing instructions on the web site to determine if the sensor is bad. If the sensor is good, call tech support to troubleshoot the panel.
	Damaged wiring between display, sensor module and/or power source.	Visually check all of the wire between the sensor, display panel and power source. Check that all wires are attached properly and that there is no damage.
Display does not come on at all	*12 Volts is not getting to panel or *Electrical shock may have fried panel	Check the inline fuse to see if it has blown. If you are measuring 12 volts going into the circuit board at the board itself (measure on the silver fingers on the board at the red wire) and the display does not come on at all, call our technicians to send it in for diagnoses and repair.
Tanks have inaccurate readings but the raw reading changes during filling and emptying.	You may have too little aluminum tape on your tank. (See the <i>Calibration notes</i> in the installation guide).	If the raw readings for empty and full are very close (less than 50 difference), you can add tape to raise the voltage signals for the sensor. You will want to try to make the raw reading difference between empty and full at least a 50 count (100 is best). Add tape, recalibrate and check again.
	You may have too much aluminum tape on your tank	If you are getting a pulsing voltage reading (using a DC volt meter across the blue and black wires while tank is selected on panel) of over 5 volts, then you may have too much tape on your tank. To remove tape, use a razor blade and run it from top to bottom. Use a ruler to keep a straight line.
	Your tank may be improperly calibrated.	See above for Improperly Calibrated Tank – you may need to change from “Empty/Full” calibration to 25% or 10% calibration settings if it is giving you non-linear readings.



Partial Accessories & Parts Order Form Price List

Item	Description	Price Each	Quantity
Moda Sensor*	Exterior Moda sensor	\$27.00	
Moda Sensor Kit*	Moda sensor with 4½' aluminum tape	\$35.00	
Moda Sensor Repair Kit*	2 – 5½" wires soldered to copper pads & 2 Butt Connectors	\$5.00	
Moda Sensor Repair Kit with aluminum tape*	2 – 5½" wires soldered to copper pads and 4½' of aluminum tape & 2 Butt Conn.	\$15.00	
PVC Sensor Rod (interior) measure from top outside of tank to bottom inside - minus ½"	Up to 12"	\$52.00	_____ "
	12¼"-24"	\$55.00	_____ "
	24¼"-36"	\$58.00	_____ "
	36¼"-50"	\$60.00	_____ "
Aluminum Diesel Rod (interior) measure from top outside of tank to bottom inside - minus ½"	Up to 12"	\$129.00	_____ "
	12¼"-24"	\$139.00	_____ "
	24¼"-36"	\$149.00	_____ "
	36¼"-50"	\$159.00	_____ "
Water Pump Switch (iSeries only)	3 Prong red lighted on/off	\$8.00	
Water Heater Switch (iSeries only)	2 large 2 small prong lighted on/off	\$8.00	
Generator Switch (iSeries only)	3 Prong green lighted on/off	\$8.00	
Fuses*	2 - ½ Amp 3AG Fuses	\$4.00	
Fuse Assembly*	Full Fuse link assembly w/ ½ Amp Fuse & wires	\$15.00	
Copper/Wire Jumper Set*	2 wires soldered to copper pads at each end for "step out" tanks. These are custom ordered to length.	\$0.00 See tech support page on web site for more info.	

***To save on shipping cost, these items can easily be put in the mail. If you would like that shipping method, please specify that option when ordering.**

You can place your order online at www.TankEdge.com or call us at: **(541) 610-0401**.

You can also mail this in to us at: Tech-Edge Manufacturing LLC *Other Accessories
 4296 Osage St. Available on the
 Sweet Home, OR 97386 web site.

Name: _____ Phone Number _____

Shipping Address: _____

CC Address (if different): _____

Credit Card # _____ Exp. _____ CCV _____

**DO NOT RETURN DEFECTIVE PARTS
TO YOUR PLACE OF PURCHASE! STOP**
1 YEAR LIMITED WARRANTY

Your monitor is warranted by Tech-Edge Manufacturing LLC for the period of 1 year from the date it was purchased by you, the original owner, to be free from defects in materials or workmanship under normal use. This warranty does NOT include labor charges or damage resulting from accident, misuse, improper installation, abuse, lack of reasonable care or electrical shock. If your product was damaged in transit, please file a claim with the carrier.

Tech-Edge Manufacturing LLC is not responsible for incidental or consequential damages resulting from installation or use of our products.

Except as provided above, no warranty or affirmation of fact, express or implied is made or authorized by Tech-Edge Manufacturing LLC. This warranty gives purchasers specific legal rights. Purchaser may also have other rights which vary from state to state. Certain aspects of disclaimers are not applicable to consumer products; e.g. (A) Some states do not allow the exclusion or limitation of accidental or consequential damages, so the above limitation may not apply to you; (B) Also, some states do not allow limitations on how long an implied warranty lasts, consequently the above limitation may not apply to you; and, by law, during the period of this warranty, any implied warranties or merchantability of fitness for a particular purpose applicable to consumer products purchased by consumers, may not be excluded or otherwise disclaimed.

This warranty is valid and transferrable from the original purchase date from an authorized reseller. Tech-Edge Manufacturing LLC will make a good faith effort to process any claim which proves to be defective within the warranty limitations.

WARRANTY PROCEDURES: Should you discover a defect in the tank monitor system during the warranty period, please check your manual and/or our web site for troubleshooting information. If you can not solve your problem with those tips, PLEASE THEN CONTACT TECH-EDGE MANUFACTURING LLC. at **(541) 610-0401**. At our discretion we will request the part be sent to us or we may direct you to the nearest AUTHORIZED Service Center for repair. If you are directed to send in your product to us, please do the following:

- 1) Send ONLY the part which is defective, COMPLETE KITS WILL NOT BE SENT AS REPLACEMENT.
- 2) Include your proof of purchase from an authorized reseller or the 1 year warranty period will be from the manufacture date.

After return has been authorized, send to: Tech-Edge Manufacturing LLC
Attn: Repairs
4296 Osage St.
Sweet Home, OR 97386

Web site: www.TankEdge.com

Peak season repairs can take up to 3 to 4 weeks to process. Call for a better estimate on your repair time.